

**GLASS PASSIVATED JUNCTION TRANSIENT VOLTAGE SUPPRESSOR
VOLTAGE-5.0 TO 190 VOLTS
200 WATTS PEAK POWER 1.0 WATT STEADY STATE**

FEATURES

- * Plastic package
- * 200W surge on 10/1000 uS waveform
- * Glass passivated chip junction in SOD-123F Package
- * Excellent clamping capability
- * Low Zener Impedance
- * High temperature soldering guaranteed: 260 °C/10 second
- * P/N suffix V means AEC-Q101 qualified, e.g:SMF5.0AV
- * Halogen-free

MAXIMUM RATINGS AND ELECTRICAL CHARACTERISTICS

Ratings at 25°C ambient temperature unless otherwise specified.
Single phase, half wave, 60 Hz, resistive or inductive load.
For capacitive load, derate current by 20%.

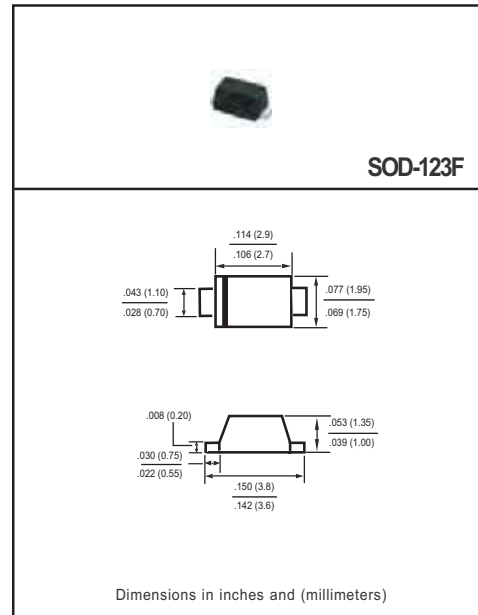

DEVICES FOR BIDIRECTIONAL APPLICATIONS

For Bidirectional use C Suffix (ex. SMF5.0CA). Electrical characteristics apply in both directions.

MAXIMUM RATINGS (At TA = 25°C unless otherwise noted)

RATINGS	SYMBOL	VALUE	UNITS
Peak Power Dissipation On 10/1000 uS Waveform	PPK	Minimum 200	Watts
Steady State Power Dissipation at TL = 75°C	Pd	1.0	Watts
ESD voltage (Contact discharge)	VESD	±8	kV
ESD voltage (Air discharge)		±15	kV
Peak Forward Surge Current 8.3ms Single Half Sine-Wave Superimposed on Rated Load	IFSM	20	Amps
Typical Current Squared Time	I ² t	1.66	A ² S
Operating and Storage Temperature Range	TJ, TSTG	-65 to +175	°C

Part Number	Reverse Stand-off Voltage	Breakdown Voltage		Test Current	Reverse Leakage		MaxClamp Voltage	Peak Pulse Current
	V _{RWM}	V _{BR} @ I _T		I _T	I _r @ V _{RWM}		V _c @ I _{PP}	I _{PP}
		Min	Max		UNI	BI		
UNI	V	V	V	mA	µA	µA	V	A
200 W Transient Voltage Suppressors								
SMF5.0A	5.0	6.40	7.07	10.0	800.0	1600.0	9.2	21.7
SMF 6.0A	6.0	6.67	7.37	10.0	800.0	1600.0	10.3	19.4
SMF 6.5A	6.5	7.22	7.98	10.0	500.0	1000.0	11.2	17.9
SMF7.0A	7.0	7.78	8.60	10.0	200.0	400.0	12.0	16.7
SMF7.5A	7.5	8.33	9.21	1.0	100.0	200.0	12.9	15.5
SMF8.0A	8.0	8.89	9.83	1.0	50.0	100.0	13.6	14.7
SMF8.5A	8.5	9.44	10.40	1.0	10.0	20.0	14.4	13.9
SMF9.0A	9.0	10.00	11.10	1.0	5.0	10.0	15.4	13.0
SMF10A	10.0	11.10	12.30	1.0	5.0	10.0	17.0	11.8
SMF11A	11.0	12.20	13.50	1.0	5.0	5.0	18.2	11.0
SMF12A	12.0	13.30	14.70	1.0	5.0	5.0	19.9	10.1
SMF13A	13.0	14.40	15.90	1.0	5.0	5.0	21.5	9.30
SMF14A	14.0	15.60	17.20	1.0	5.0	5.0	23.2	8.62
SMF15A	15.0	16.70	18.50	1.0	5.0	5.0	24.4	8.20
SMF16A	16.0	17.80	19.70	1.0	5.0	5.0	26.0	7.69
SMF17A	17.0	18.90	20.90	1.0	5.0	5.0	27.6	7.25
SMF18A	18.0	20.00	22.10	1.0	5.0	5.0	29.2	6.85
SMF19A	19.0	21.10	23.30	1.0	5.0	5.0	30.6	6.54
SMF20A	20.0	22.20	24.50	1.0	5.0	5.0	32.4	6.17
SMF22A	22.0	24.40	26.90	1.0	5.0	5.0	35.5	5.63
SMF24A	24.0	26.70	29.50	1.0	5.0	5.0	38.9	5.14
SMF26A	26.0	28.90	31.90	1.0	5.0	5.0	42.1	4.75
SMF28A	28.0	31.10	34.40	1.0	5.0	5.0	45.4	4.41
SMF30A	30.0	33.30	36.80	1.0	5.0	5.0	48.4	4.13
SMF33A	33.0	36.70	40.60	1.0	5.0	5.0	53.3	3.75
SMF36A	36.0	40.00	44.20	1.0	5.0	5.0	58.1	3.44
SMF40A	40.0	44.4	49.1	1.0	5.0	5.0	64.5	3.10
SMF43A	43.0	47.8	52.8	1.0	5.0	5.0	69.4	2.88
SMF45A	45.0	50.0	55.3	1.0	5.0	5.0	72.7	2.75
SMF48A	48.0	53.3	58.9	1.0	5.0	5.0	77.4	2.58
SMF51A	51.0	56.7	62.7	1.0	5.0	5.0	82.4	2.43
SMF54A	54.0	60.0	66.3	1.0	5.0	5.0	87.1	2.30
SMF58A	58.0	64.4	71.2	1.0	5.0	5.0	93.6	2.14
SMF60A	60.0	66.7	73.7	1.0	5.0	5.0	96.8	2.07
SMF64A	64.0	71.1	78.6	1.0	5.0	5.0	103.0	1.94
SMF70A	70.0	77.8	86.0	1.0	5.0	5.0	113.0	1.77
SMF75A	75.0	83.3	92.1	1.0	5.0	5.0	121.0	1.65
SMF78A	78.0	86.7	95.8	1.0	5.0	5.0	126.0	1.59
SMF80A	80.0	88.8	97.6	1.0	5.0	5.0	129.0	1.55
SMF85A	85.0	94.4	104.0	1.0	5.0	5.0	137.0	1.46
SMF90A	90.0	100.0	111.0	1.0	5.0	5.0	146.0	1.37
SMF100A	100.0	111.0	123.0	1.0	5.0	5.0	162.0	1.23

Part Number	Reverse Stand-off Voltage	Breakdown Voltage		Test Current	Reverse Leakage		Max. Clamp Voltage	Peak Pulse Current
	V _{RWM}	V _{BR} @ I _T		I _T	I _R @ V _{RWM}		V _C @ I _{PP}	I _{PP} Min
		Min	Max		UNI	BI		
UNI	V	V	V	mA	μA	μA	V	A
200 W Transient Voltage Suppressors								
SMF110A	110.0	122.0	135.0	1.0	5.0	5.0	177.0	1.13
SMF120A	120.0	133.0	147.0	1.0	5.0	5.0	193.0	1.04
SMF130A	130.0	144.0	159.0	1.0	5.0	5.0	209.0	0.96
SMF140A	140.0	155.0	171.0	1.0	5.0	5.0	224.0	0.89
SMF150A	150.0	167.0	185.0	1.0	5.0	5.0	243.0	0.82
SMF160A	160.0	178.0	197.0	1.0	5.0	5.0	259.0	0.77
SMF170A	170.0	189.0	209.0	1.0	5.0	5.0	275.0	0.73
SMF180A	180.0	201.0	222.0	1.0	5.0	5.0	292.0	0.69
SMF190A	190.0	211.0	232.0	1.0	5.0	5.0	324.0	0.62

NOTE : 1. V_F = 3.5V AT I_F = 12A ON 1/2 SQUARE OR EQUIVALENT SINE WAVE. PW = 8.3mS, DUTY CYCLE = 4 PULSES PER MINUTE
MAXIMUM

2. MOUNTED ON 5.0mm² COPPER PADS TO EACH TERMINAL

RATING AND CHARACTERISTIC CURVES (SMF5.0ATHRU SMF190A)

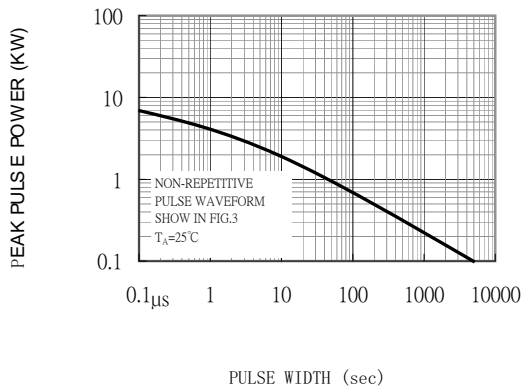

FIG. 1 - PEAK PULSE POWER RATING CURVE

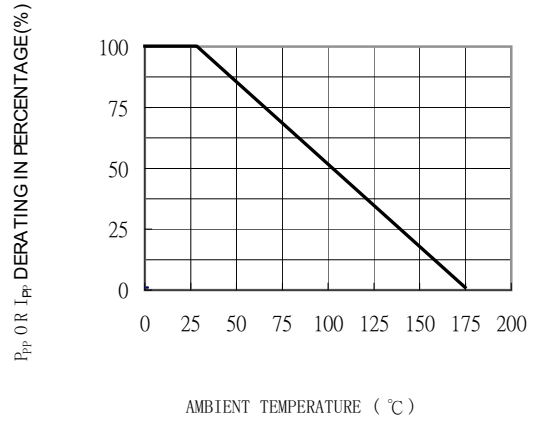

FIG. 2 - PULSE DERATING CURVE

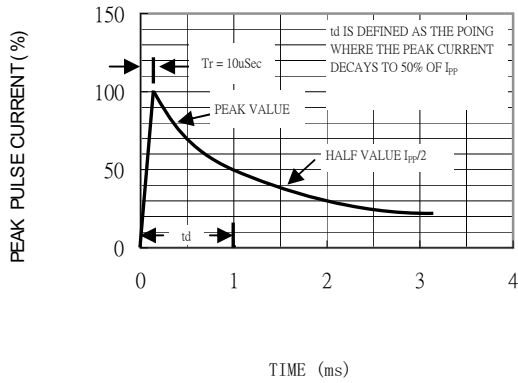

FIG. 3 - PULSE WAVEFORM

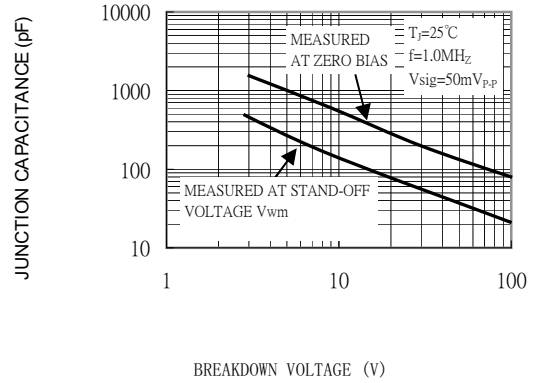

FIG. 4 - TYPICAL JUNCTION CAPACITANCE

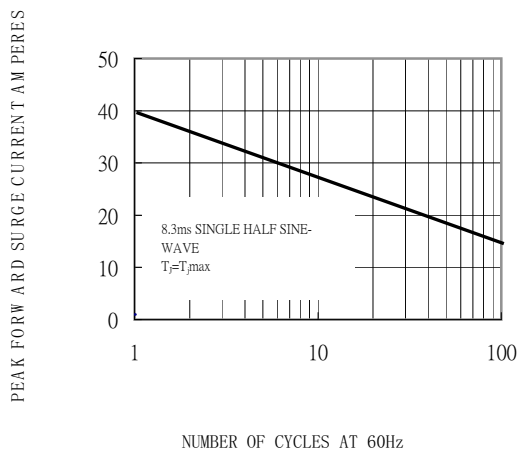
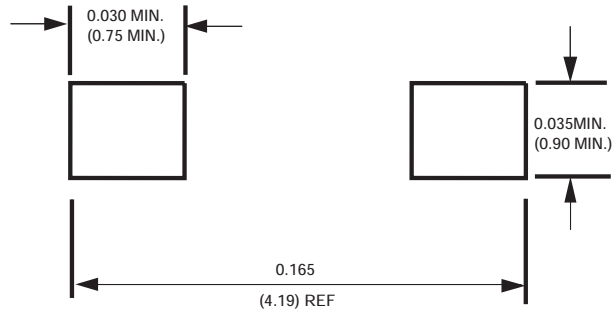

FIG. 5 - MAXIMUM NON-REPETITIVE PEAK FORWARD SURGE CURRENT UNIDIRECTIONAL ONLY

Mounting Pad Layout



Dimensions in inches and (millimeters)



RECTRON

Attachment information about SMFXXX

1. Internal Circuit



2. Marking on the body

1) SMFXXXA

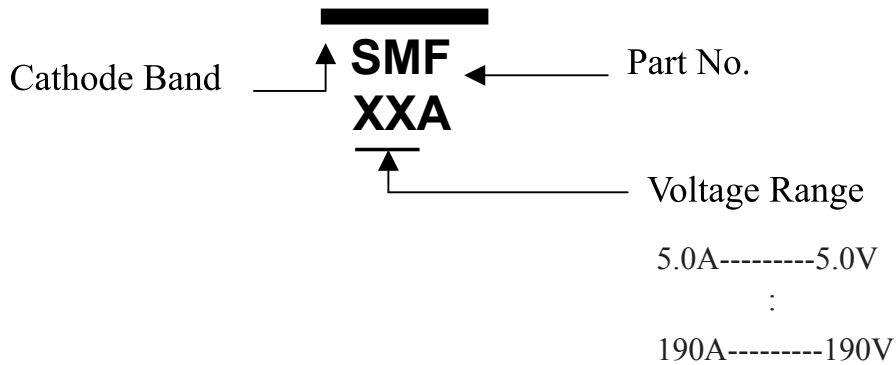

2) SMFXXXCA

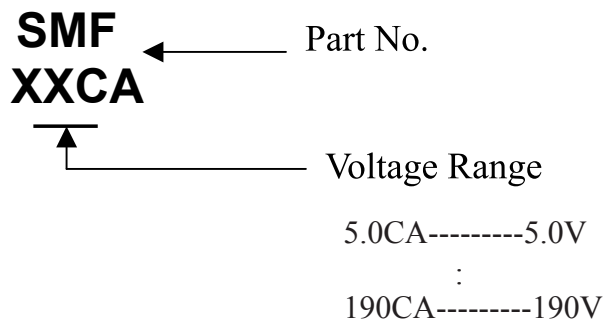

PACKAGING OF DIODE AND BRIDGE RECTIFIERS

REEL PACK

PACKAGE	PACKING CODE	EA PER REEL	EA PER INNER BOX	COMPONENT SPACE (mm)	TAPE SPACE (mm)	REEL DIA (mm)	CARTON SIZE (mm)	EA PER CARTON	GROSS WEIGHT(Kg)
SOD-123F/ SOD-123FL	-W/T	3,000	15,000	---	---	178	390*205*310	120,000	6.964

DISCLAIMER NOTICE

Rectron Inc reserves the right to make changes without notice to any product specification herein, to make corrections, modifications, enhancements or other changes. Rectron Inc or anyone on its behalf assumes no responsibility or liability for any errors or inaccuracies. Data sheet specifications and its information contained are intended to provide a product description only. "Typical" parameters which may be included on RECTRON data sheets and/ or specifications can and do vary in different applications and actual performance may vary over time. Rectron Inc does not assume any liability arising out of the application or use of any product or circuit.

Rectron products are not designed, intended or authorized for use in medical, life-saving implant or other applications intended for life-sustaining or other related applications where a failure or malfunction of component or circuitry may directly or indirectly cause injury or threaten a life without expressed written approval of Rectron Inc. Customers using or selling Rectron components for use in such applications do so at their own risk and shall agree to fully indemnify Rectron Inc and its subsidiaries harmless against all claims, damages and expenditures.